

Instruction Manual



Southern Pacific 4-8-8-2 Cab Forward Live Steam



ACCUCRAFT TRAINS
MUSEUM QUALITY BRASS MODELS

Cab Forward Live Steam - Butane Fired



Prototype Information

Those of us fortunate enough to have seen Cab forward in action will never forget their massive size and thunderous sound. Standing next to the tracks on Donner Pass in the Sierra Nevada with Cab Forwards pounding up grade, hauling long strings of PFE reefer blocks, was truly an awesome sight. The ground literally shook as they went by.

The design of the Cab Forward was done out of necessity. By reversing the locomotive end for end and placing the cab in front the exhaust gases from the stack were behind the crew. This was necessary in the long covered snow sheds to keep the crew from being asphyxiated.

Our two Cab Forward models are unique in that the 4294 was the last Cab Forward to be built and the last steam engine purchased by the Southern Pacific. The 4274 was the last Cab Forward shopped by Southern Pacific for the last Railfan Trip over Donner Pass, as well as the last Cab Forward to operate on the Southern Pacific Railroad. It was unfortunate that the 4274 was not saved from being scrapped, as the engine went back to the dead line after the trip and was scrapped soon after. What a waste!

Cab Forward Live Steam - Butane Fired



General Information about Accucraft Cab Forward Model:

Operating a model live-steam locomotive is much different from running an electrically powered engine. It is a more hands-on, interactive experience. The locomotive must be periodically fueled, oiled, and watered. As supplied, the Cab Forward is manually controlled, which means that you must actually drive the locomotive using the controls in the cab, just as you would a full-size engine.

The performance of the engine is also unlike electric locomotives. The Cab Forward should pull a 30 or more standard-size freight cars on good, level track. Grades and sharp curves will diminish its capability. A good engineer will learn the engine's characteristics and idiosyncrasies over time, to get the best performance and longest duration from it.

Safety

For your safety, there are certain rules that should be observed, as follows:

1. The safety valves are set differently. The safety valve in the cab is set for 100 lbs. The main safety valves a top the boiler is set for 65lbs. More about the safety valves later.

2. The firing system has been designed to use butane gas only. Do not use any other gas (including propane or butane/propane mix), as the storage

pressures can reach unsafe levels.

3. Always refuel the engine well away from other working live-steam locomotives. The fuel filling system allows a small amount of the gas to bleed off as the fuel tank is being filled. A passing engine can ignite this bleed-off gas, causing a potentially hazardous situation.

4. When lighting up, light your match first, then turn on the gas.

5. A steam engine gets hot. Be careful.

Carrying the Engine

The locomotive and tender should always be carried separately because of their weight. We suggest carrying the locomotive to the track by supporting it underneath the wheels with both hands, as opposed to lifting by the pilot (which may not stand the stress) and rear beam. For general carrying, the engine can be carried on a carrying tray with handles.

Cab Forward Live Steam - Butane Fired



Operation

1. Oil all external moving parts of the engine and tender with a high grade, lightweight machine oil like 3-in-1. Don't forget the wheel bearings in the pilot and trailing trucks, as well as those in the tender. Don't over-oil; a tiny drop will do the job.

2. Place the engine and tender on the track and couple them together. The drawbar between the units has two holes. For tighter curves, use the rear hole. For wide-radius curves, the engine and tender can be coupled more closely together, using the front hole.

The Butane, water feed, and water return lines need to be connected from the tender to the locomotive. The center hose should go straight across to the center position on the locomotive. This is the butane connection. The water feed line will be the right side connection and the water by-pass return line is the left side connection. The hoses need to be slid on over the expanded portion of the fitting and the knurled ring tighten down over the hose and expanded portion of the fitting. This is most important on the right side water feed. This hose can have a great deal of pressure in it. When using the hand pump the pump has to pump at a higher pressure than what the boiler pressure is at that time. So you can pump as much as 100 lbs.

per square inch through this right side line. The center fuel line has fairly low pressure as the Butane flows through it and the return line is only pumping at a few lbs. of pressure.

Lubricator

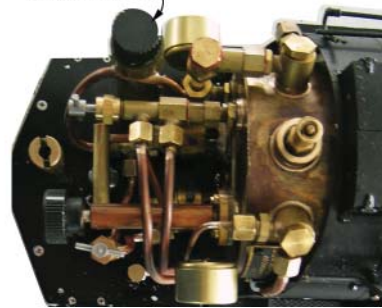

3. The displacement lubricator is located in the cab (see figure 1). This lubricator ensures the cylinders and valves are properly lubricated inside. As the steam passes through it, a small amount will condense into water. This water will sink to the bottom of the lubricator, forcing a similar quantity of oil into the steam line and thus to the cylinders. Remove the lubricator's cap and draw out any water from the previous run with a syringe. Fill the lubricator to the top with proper steam cylinder oil.

4. The cab mounted safety valve has two functions. It is used as the filler plug to fill the boiler with water when the engine is cold. You can fill the boiler with distilled water up to the top of the sight glass through this opening. Also the 2nd safety valves pres-

Cab Forward Live Steam - Butane Fired



sure has been set much higher than the main safety valve out on top of the boiler. It is simply there for double redundancy in case the other valve fails in the closed position. This very seldom happens however having the 2nd valve gives an extra measure of safety. This was done to keep the scale original appearance of the turret on top of the boiler as two safety valves would not fit into that space.



This is a BIG locomotive and it will take a lot of water.

Do not over fill the boiler, there needs to be room above the water for steam to form.

Use only distilled water in your engine's boiler. Tap water contains minerals and will leach out, could cloud the water glass, clog the axle pump and ultimately affect the performance of the engine.

5. Finally, add fuel. Your Cab Forward

burns butane gas.

The gas tank is located in the tender beneath the Oil Bunker. Butane gas can be purchased at the grocery store or at a tobacconist's as cigarette-lighter refills.

These come with a nipple suitable for the filler valve on the Cab Forward's gas tank. (Butane can also be purchased more economically in larger containers at camping-supply stores, but these cans will require a special adapter for filling the engine's tank.) Simply press the nozzle of the butane canister hard onto the filler valve atop the tank, making sure that the control valve is closed.

You will hear the gas transferring and will see a little gas bleeding out of the valve. The gas may tend to sputter a little from time to time while filling. When the tank is full, the gas will begin to splutter a lot and much more gas will escape the valve. When the gas tank is full you are ready to fire up the engine.

NOTE: Because of the size of this locomotive and the fact that it has two

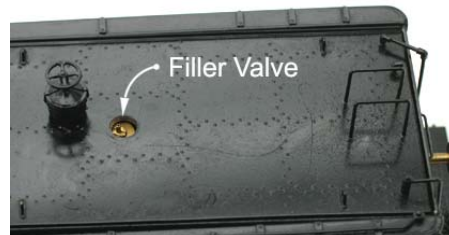

Cab Forward Live Steam - Butane Fired



burners, a very large gas tank has been provided, which takes a while to fill completely.

If you find that you are getting relatively short runs and there is still a lot of water left in the boiler, chances are that you didn't fill the gas tank all the way. Now fill the tender with distilled water.

Firing Up

The engine's burners reside at the back of the flues inside the boiler. Open the hinged smokebox door at the back of the engine and you'll be able to see both flues.

To light up, strike a match and hold it at the open smokebox door while simultaneously opening the gas valve in the tender very slowly until the gas ignites. You should hear the gas coming into the burner.

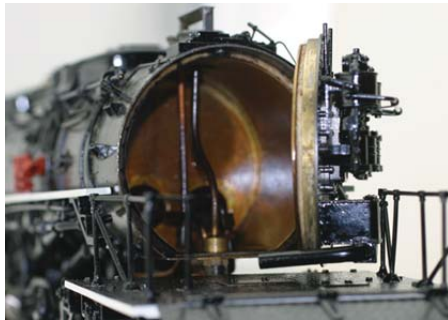

Opening the valve too wide or too fast may blow out the flame or cause the fire to burn in the smokebox.

The fire should flash back into the back of the flues with a quiet "pop". If it wants to burn in the smokebox or in the forward part of the flues, slowly close the gas valve until it flashes back to the burner.

Don't let the fire burn in the smokebox your engine will not run as it should and may be damaged.

The fire should burn in crescent-shaped flames that should be clearly visible through the smokebox door. The flames should be bright blue and should burn steadily. If they sputter or look yellow or green, adjust the gas valve accordingly.

The object is to run the burner at the lowest setting possible to operate the engine, thereby increasing the efficiency of the engine and the duration of the run. You'll get the hang of this with practice.

Make certain that both burners have ignited by looking down the flues at the fires. If only one burner is lit, simply strike another match and put the flame in the smokebox. This should ignite the second burner. If a burner goes out while the engine is in operation (you might be able to tell by the sound of the fire or by sluggish performance) it must be manually relit. One burner will not automatically ignite the other.

Cab Forward Live Steam - Butane Fired



After ten or twelve minutes, pressure on the pressure gauge should read about 20psi (pounds per square inch) or so. The main safety valve is set at 65psi. When the pressure on the gauge reaches 50psi, the engine can be run.

A dental mirror makes checking the fire on both flues easier to see and adjust.

Axle Pump

This locomotive is equipped with an axle pump and bypass valve. The pump moves water from the tender to a check valve on the locomotive. The bypass valve is located in the cab.

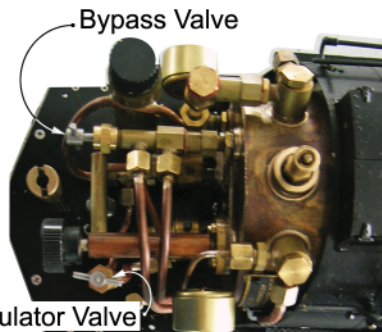

When the bypass valve is completely shut, the pump pumps water into the locomotive. When the bypass valve is open, the pump will re-circulate water back into the tender. With careful adjustment of this valve, the engine will always have enough water to keep running for long periods of time un-

til the tender water tank needs to be refilled. The tender is also equipped with the hand pump, which needs to be used to prime the axle pump. Only two or three strokes are necessary to prime the pump.

A new feature on this articulated live steam locomotive is the rear engine steam regulator valve. This valve allows you regulate the amount of steam to the rear engine if it starts to lose traction and slip. This control is located in the cab.

Shutting Down

To shut the engine down, simply close the gas valve and allow the engine to run off any residual steam. At the end of the run, open the blowdown valve and leave it open. This will relieve the boiler of what little pressure remains and prevent a vacuum from forming inside that could draw lubricating oil into the boiler if the throttle valve is not fully closed. Because of the size of this engine, blowing down could take



Cab Forward Live Steam - Butane Fired



several minutes.

After a day's operation in the garden, you'll probably find that your engine has a coating of oil all over it. This is steam-cylinder oil that has been exhausted from the stack. A simple wipe down with a dry cloth is all that's necessary to restore the engine to pristine condition. This is best done while the engine is still warm. Wipe any grit and excess oil from the wheels and running gear.

Cold-Weather Running

The weather can dramatically affect the performance of your locomotive. Cold and wind can decrease efficiency to a disappointing level. Butane gas becomes liquid at 32°F and will not work. As it approaches 32°, its pressure (and effectiveness) diminishes.

The compartment in the tender in which the gas tank resides can be filled with warm water in cooler weather. This will warm the gas in the tank and keep its pressure up, which will cause the engine to operate in a much more lively manner, much as it does in warm weather. If the water in the tank cools, just replace it with warmer water. Empty the tender at the end of the day's run. Note: the temperature of the fuel-supply-can must always be higher than that of the engine's gas tank. If you have warmed the engine's

gas tank and the supply can is cooler, gas will not transfer. Never put hot water in the tender around the fuel tank.

Notes on Radio Control

Although the Cab Forward was designed as a manually controlled locomotive, there is no reason why radio control (R/C) cannot be fitted, with some ingenuity. A two-channel radio is all that's necessary, one for the throttle and one for the reversing lever. The gas valve should always be controlled manually.

Cab Forward Live Steam - Butane Fired



Technical Specifications

Scale/Gauge: 1/32, 45 mm Gauge
Total Weight: 16.6 kg, 36.5 lbs.

Engine Length: 38 in. (965.2 mm)
Engine Width: 4.5 in. (114.3 mm)
Engine Height: 6.5 in. (165.1 mm)

Tender information:

Tender Length: 18 in. (457.2 mm)
Tender Width: 4.25 in. (107.9 mm)
Tender Height: 6.5 in. (165.1 mm)
Recommended radius: 3 M, 10 ft.

*Be sure to leave at least 3" clearance (measured from the inner rail) to allow for overhang.

Caution!

This model is an accurate replica of the original locomotive. It has sharp and moving parts. The locomotive drive rods are stainless steel with sharp edges. AT ANY TIME, OPERATORS MUST NOT COME IN CONTACT WITH THE MODEL WHILE IT IS POWERED. UNDER NO CIRCUMSTANCES SHALL ACCUCRAFT TRAINS BE RESPONSIBLE FOR ANY INCIDENTAL OR CONSEQUENTIAL DAMAGES ARISING IN REGARD TO ANY ACCUCRAFT PRODUCT.

Cab Forward Live Steam - Butane Fired



Accucraft Trains locomotives are fine scale brass models with small parts. To provide maximum protection from shipping damage, we carefully pack the models in metal cases. We ship via UPS with insurance coverage to its full value. Please contact UPS if package is damaged.

Each locomotive is packed under UPS guideline for shipping. We do not warrant any damage resulted from re-packaging by any party other than Accucraft Trains.

Please read following directions before unpacking your locomotive.

1. Remove foam around the locomotive. Slide the inner box cover to the side, and open the inside cardboard box with a cutting knife.

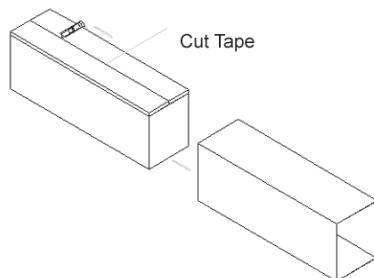

2. Lift the metal case from the cardboard box.

3. The locomotive is firmly taped to a 1/2" wood board which is then fastened to the metal case with 4 M6 bolts.

Bolts must be removed before lifting the locomotive with wood board from the metal case.

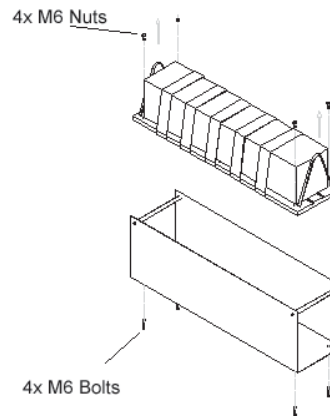

4. Place taped locomotive on a flat surface. Carefully cut the tape along the wood board side surface. Be sure to cut both sides of the wood board. Slowly lift the tape from the locomotive. Be very careful with small parts. Tape cannot be re-used to re-pack the model. Use new packing tape if necessary.

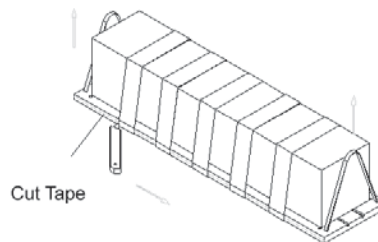

Cab Forward Live Steam - Butane Fired



NOTES:



ACCUCRAFT COMPANY
33268 Central Avenue
Union City, CA 94587
Tel: 510-324-3399
Fax: 510-324-3366
Email: info@accucraft.com
Copyright 2007